

G12 Series

Maximum Flow Rate: 33.4 l/min (8.8 gpm)

Maximum Pressure: 103 bar (1500 psi) for Metallic Pump Heads



WANNER
Hydra-Cell[®]
Seal-less Pump Technology



G12 equipped with Model C62 Pressure Regulator Valve and Tube Accessory

G12 Series Performance

Capacities

Flow

model	Max. Input rpm	Max. Flow	
		@ 69 bar (1000 psi) gpm	@ 69 bar (1000 psi) l/min
G12-X	1450	8.1	30.6
G12-E	1750	8.8	33.4
G12-S	1750	6.0	22.7
G12-I	1750	4.0	15.0

@ 103 bar (1500 psi)			
G12-X	790	4.26	15.10
G12-E	790	3.87	14.70

Pressure

Maximum Inlet Pressure
17 bar (250 psi)

Maximum Discharge Pressure
G12-X, E, S, I to 69 bar (1000 psi)
G12-X to 103 bar (1500 psi)

Performance and specification ratings apply to G12 configurations unless specifically noted otherwise.

Maximum Flow at Designated Pressure

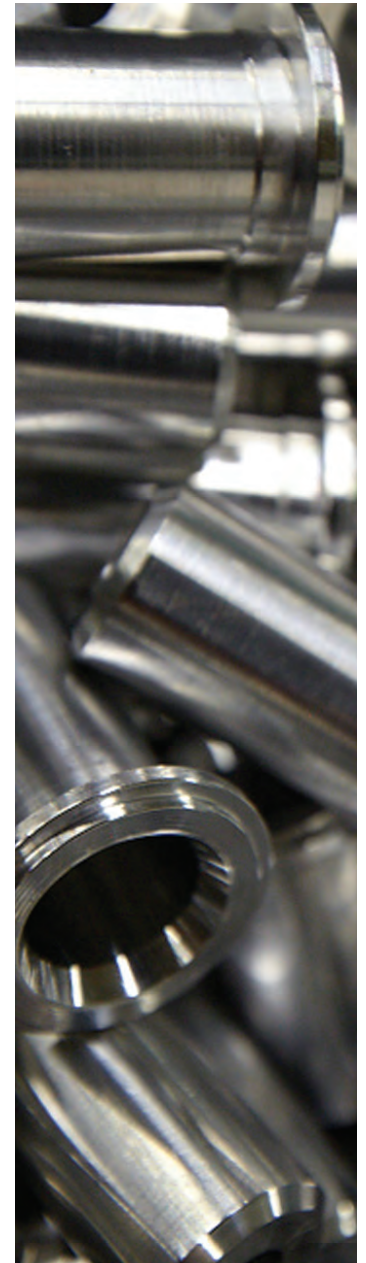
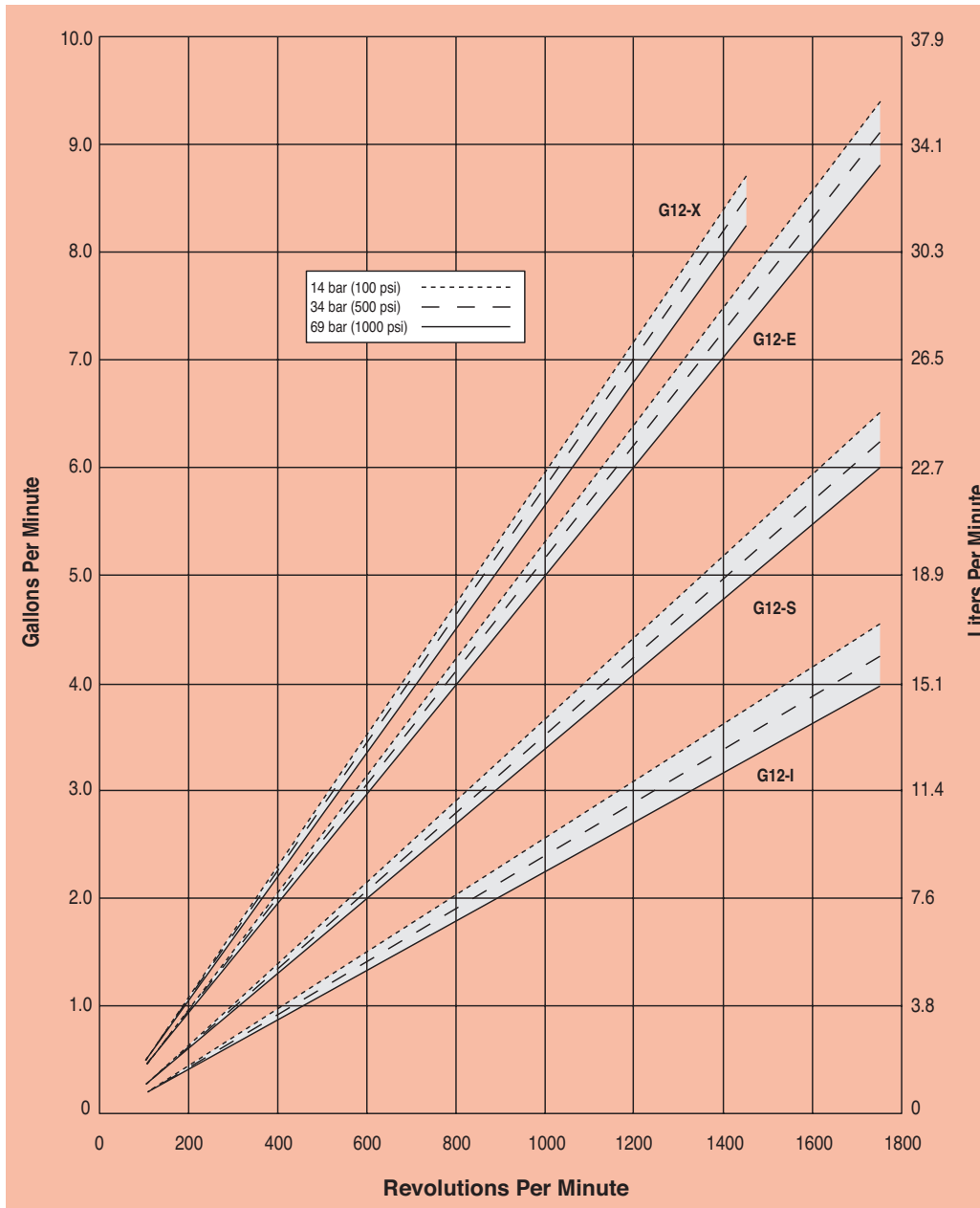

G12 Series Specifications

Flow Capacities @ 69 bar (1000 psi) 4-pole Motor @ 50 Hz

Model	rpm	gpm	l/min
G12-X	1450	8.10	30.6
G12-E	1450	6.63	25.1
G12-S	1450	4.96	18.8
G12-I	1450	3.30	12.5

Flow Capacities @ 69 bar (1000 psi) 6-pole Motor @ 50 Hz

Model	rpm	gpm	l/min
G12-X	960	5.19	19.6
G12-E	960	4.39	16.6
G12-S	960	3.28	12.4
G12-I	960	2.19	8.3

Delivery @ 69 bar (1000 psi)

Model	gal/rev	liters/rev
G12-X	0.0056	0.0211
G12-E	0.0051	0.0191
G12-S	0.0034	0.0130
G12-I	0.0023	0.0086

Maximum Discharge Pressure

Metallic Heads: 103 bar (1500 psi)

Maximum Inlet Pressure 17 bar (250 psi)

Maximum Operating Temperature

Metallic Heads: 121 °C (250 °F) - Consult factory for correct component selection for temperatures from 71 °C (160 °F) to 121 °C (250 °F).

Maximum Solids Size 500 microns

Inlet Port 1 inch BSPT

1 inch NPT

Discharge Port 3/4 inch BSPT

3/4 inch NPT

Shaft Diameter 22.2 mm (7/8 inch)

Shaft Rotation Reverse (bi-directional)

Bearings Tapered roller bearings

Oil Capacity 1.4 liters (1.5 US quarts)

Weight

Metallic Heads: 28.6 kg (63 lbs.)

Calculating Required Power

$$\frac{15 \times \text{rpm}}{63,000} + \frac{\text{gpm} \times \text{psi}}{1,460} = \text{electric motor hp}$$

$$\frac{15 \times \text{rpm}}{84,428} + \frac{\text{l/min} \times \text{bar}}{511} = \text{electric motor kW}$$

Calculating Pulley Size

$$\frac{\text{motor pulley OD}}{\text{pump rpm}} = \frac{\text{pump pulley OD}}{\text{motor rpm}}$$

When using a variable frequency controller (VFD) calculate the hp or kW at minimum and maximum pump speed to ensure the correct hp or kW motor is selected. Note that motor manufacturers typically de-rate the service factor to 1.0 when operating with a VFD.

Net Positive Suction Head (NPSHr)

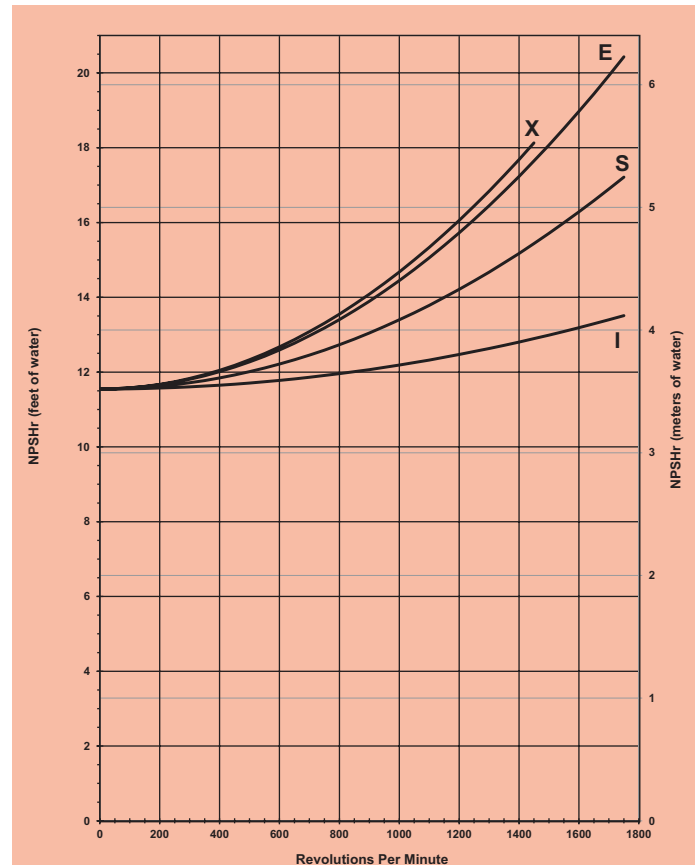

Positive inlet pressure required for:

- A) All pumps with PTFE diaphragms
- B) Pumps with I-cam (consult factory)

Self-priming:

Each Hydra-Cell pump has different lift capability depending on model size, cam angle, speed, and fluid characteristics. To ensure that your specific lift characteristics are met, refer to the inlet calculations regarding friction, and acceleration head losses in your Hydra-Cell Installation & Service Manual. Compare those calculations to the NPSHr curves above.

G12 Series Representative Drawings

G12 Standard Configuration (Metallic Pump Heads)

mm (Inches)

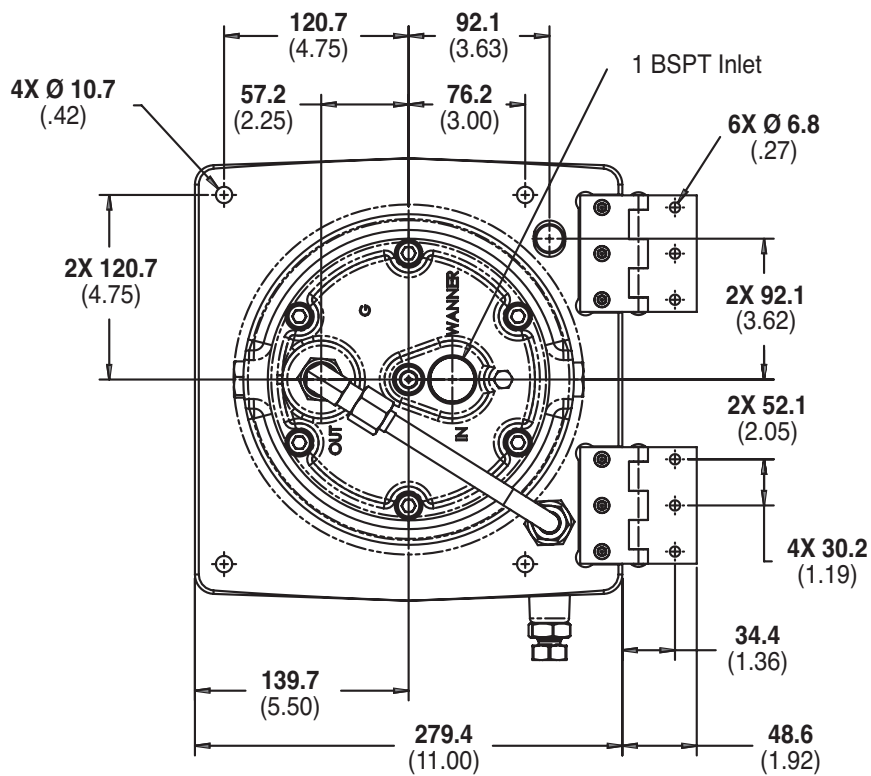
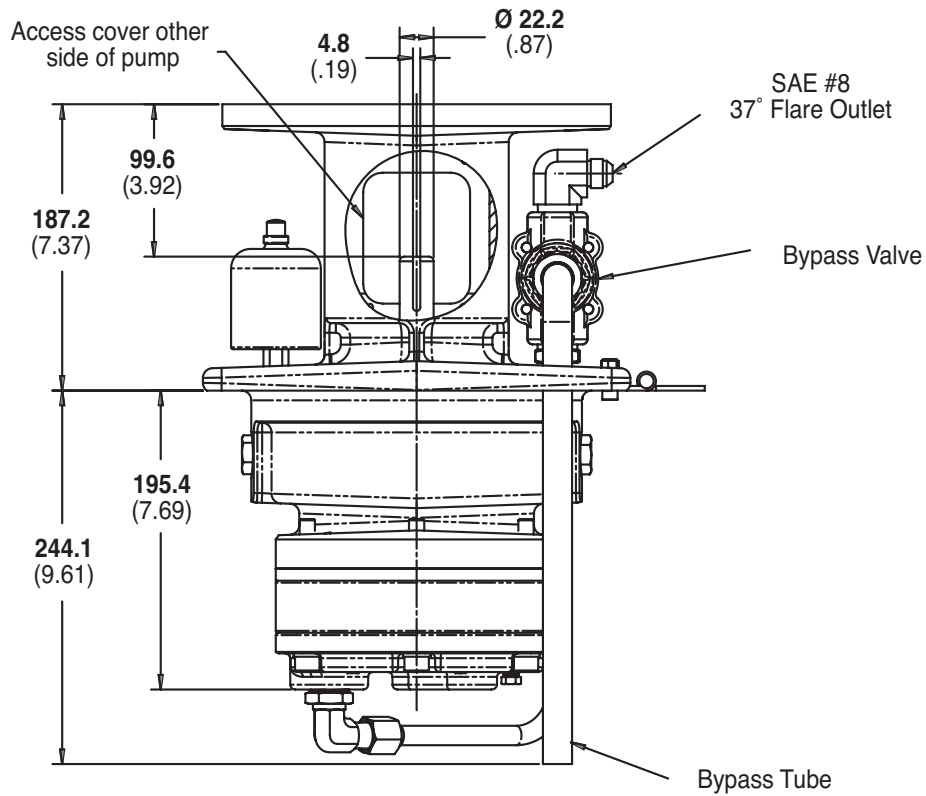

Note: Contact factory for additional drawings of specific models and configurations.

G12 Series Representative Drawings

G12 with Tube Accessory Inches (mm)

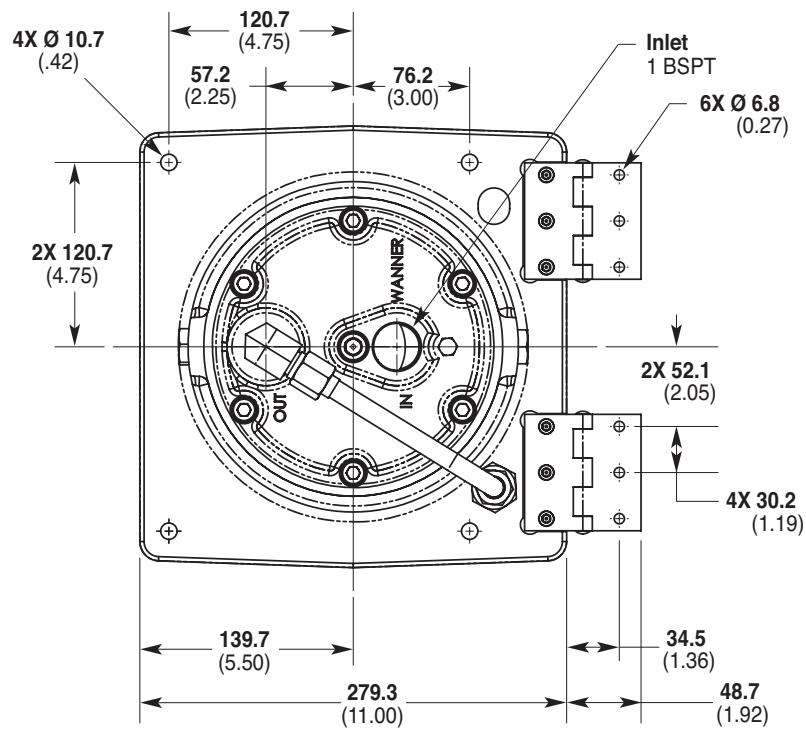
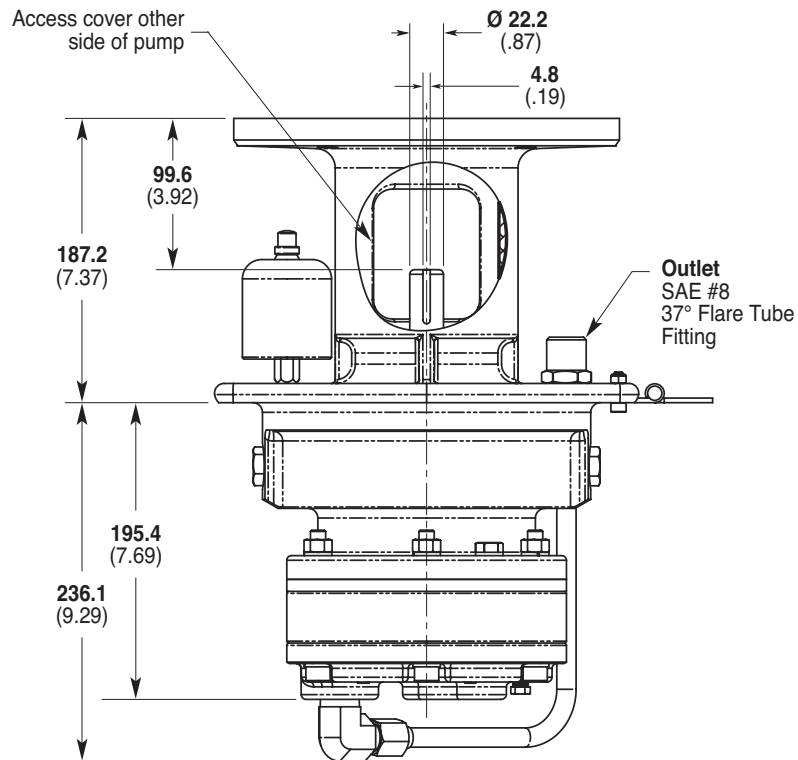

Note: Contact factory for additional drawings of specific models and configurations.

G12 Series Representative Drawings

G12 with Valve/Tube Accessory Inches (mm)

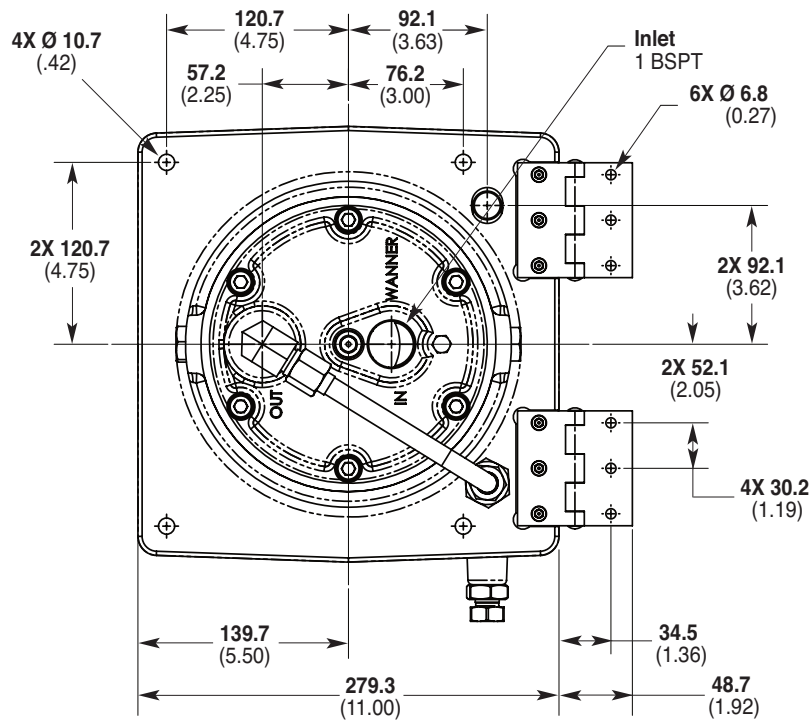
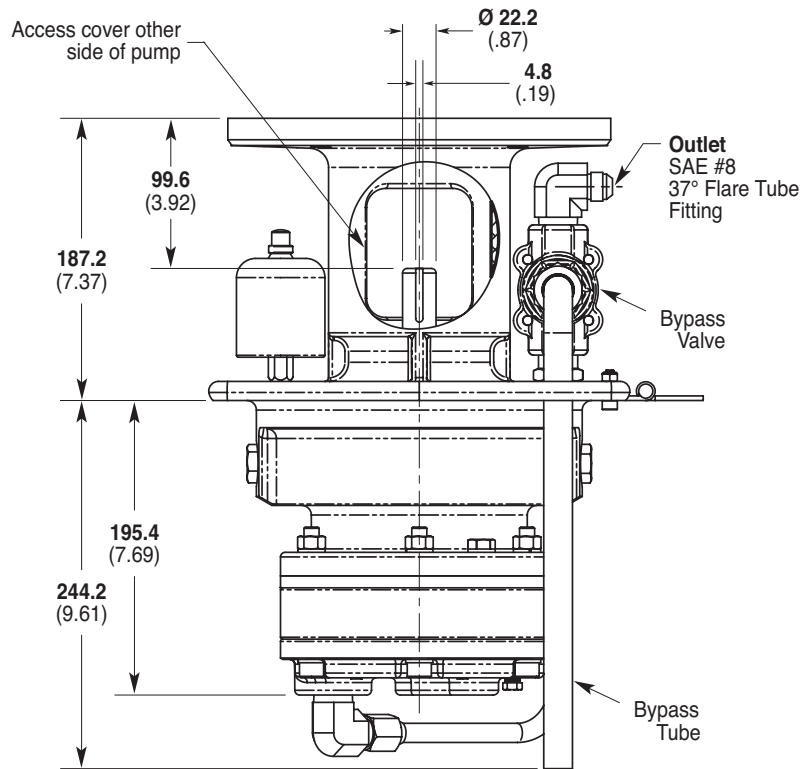

Note: Contact factory for additional drawings of specific models and configurations.

G12 Series Representative Drawings

G12 Models with Minimum Tank Size and Critical Installation Dimensions mm (Inches)

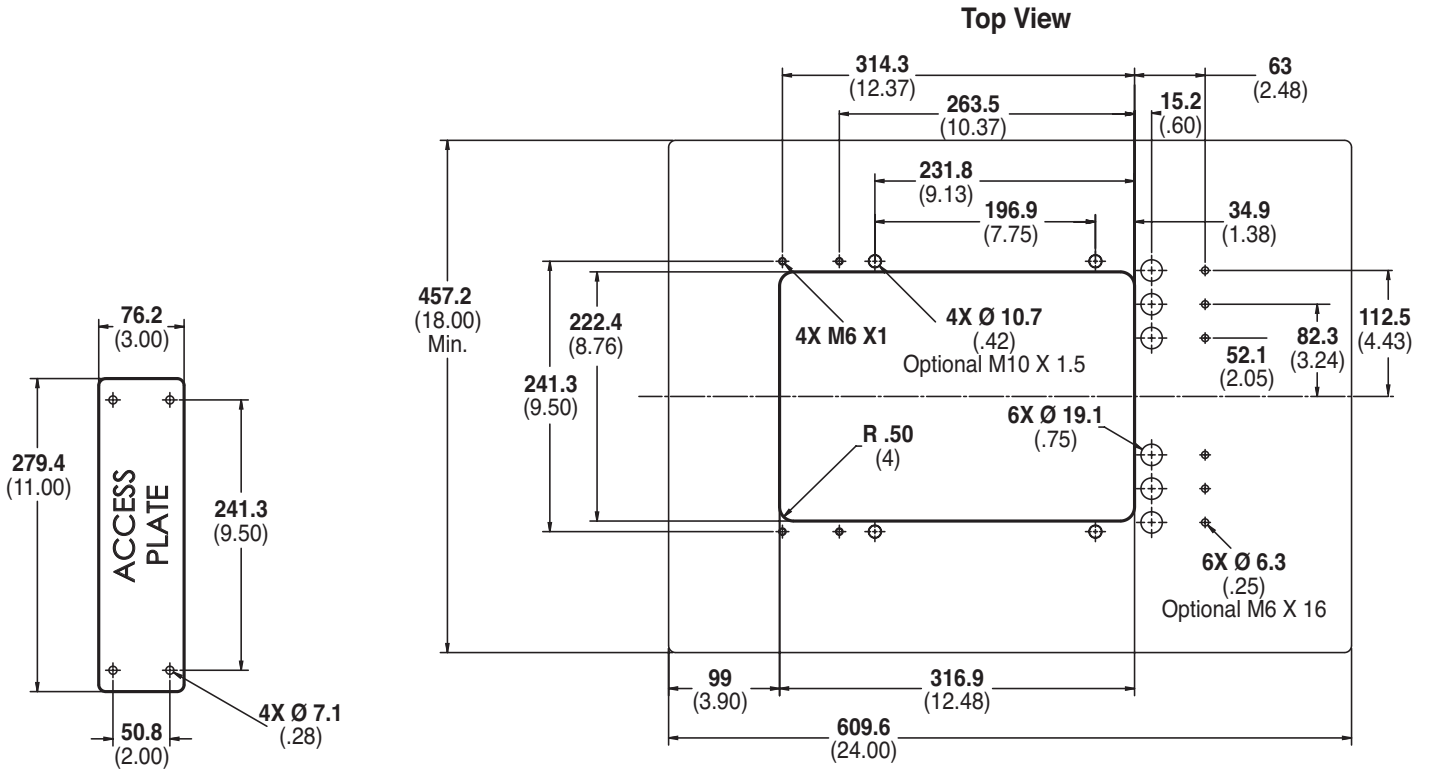

Top of tank must support weight of 91 kilograms for pump/motor

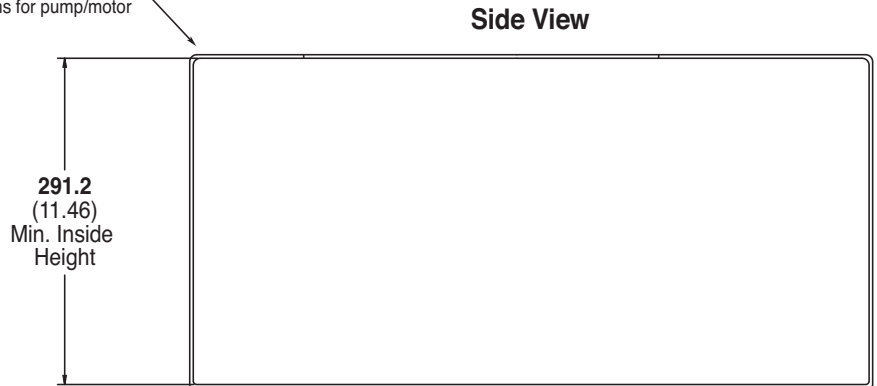

- Notes:**
- Contact factory for additional drawings of specific models and configurations.
 - Contact factory for internal tank design.

G12 Series **Valve/Tube Accessories**

The Hydra-Cell G12 Tube and Valve/Tube Accessories provide a pre-fabricated plumbing package for simplified installation.

(See page 5 for dimensions.)

Ordering Information

Tube Accessory Part Number: A04-009-1200

Valve/Tube Accessory Part Number: A04-010-1200



Valve Selection

A seal-less C62 Pressure Regulating Valve is recommended for Hydra-Cell G12 pumping systems, especially for high-pressure requirements or when handling dirty fluids.



A C22 Pressure Regulating Valve provides a capable, lower-cost alternative to C62 valves for Hydra-Cell G12 pumping systems.



G12 Series **How to Order**

Ordering Information

1	2	3	4	5	6	7	8	9	10	11	12
G	1	2									

A complete G12 Series Model Number contains 12 digits including 9 customer-specified design and materials options, for example: G12XKCGHFECA.

Digit	Order Code	Description
1-3	G12	Pump Configuration Flanged for IEC 100/112 B5 (BSPT Ports)* *Tube Accessory Kits ordered separately. See previous page. IEC 100/112 to 132 Motor Adaptor (Part No. A04-030-1012)
4	X E S I	Hydraulic End Cam Max 29.0 l/min (7.7 gpm) @ 1450 rpm Max 25.1 l/min (6.6 gpm) @ 1450 rpm Max 22.7 l/min (6.0 gpm) @ 1750 rpm Max 15.0 l/min (4.0 gpm) @ 1750 rpm
5	R -	Pump Head Version Kel-Cell, Optimised Valve Plate, BSPT Ports ATEX (Note: ATEX 94/9/EC Certified, Category 2, Zone 1. Includes certificate and oil level monitor.)
6	B C S	Pump Head Material Brass Cast Iron (Nickel-plated) 316L Stainless Steel
7	E G J P T	Diaphragm & O-ring Material EPDM (requires EPDM-compatible oil - Digit 12 oil code C) FKM PTFE (available with E and S cams only; 1200 rpm max.) Neoprene Buna-N
8	C D H S	Valve Seat Material Ceramic Tungsten Carbide 17-4 Stainless Steel 316L Stainless Steel
9	C D F N	Valve Material Ceramic Tungsten Carbide 17-4 Stainless Steel Nitronic 50
10	E	Valve Springs Elgiloy (Exceeds SST grade 316L)

Digit	Order Code	Description
11	C H M P Y	Valve Spring Retainers Celcon 17-7 Stainless Steel PVDF Polypropylene Nylon (Zytel)
12	A B C E G H	Hydra-Oil 10W30 standard-duty oil 40-wt for continuous-duty (use with 316L SST pump head - standard) EPDM-compatible oil Food-contact oil 5W30 cold-temp severe-duty synthetic oil 15W50 high-temp severe-duty synthetic oil





WANNER ENGINEERING - WORLD HEADQUARTERS & MANUFACTURING
Minneapolis USA
t: (612) 332-5681
e: sales@wannereng.com

WANNER PUMPS
Kowloon HONG KONG
t: +852 3428 6534
e: sales@wannerpumps.com

WANNER INTERNATIONAL
Hampshire UK
t: +44 (0) 1252 816847
e: sales@wannerint.com

WANNER ENGINEERING
Latin American Office
t: +55 (11) 4081-7098
e: sales@wannereng.com

WANNER PUMPS
Shanghai CHINA
t: +86-21-6876 3700
e: sales@wannerpumps.com